

1750nm High Power Isolator (HPIS / HPMIS)

Features

Wide Operating Wavelength
 High Isolation & High PER
 Telcordia GR-1221 Compliant
 Available for Both Axes Pass or Fast Axis Block

Application

High Power Amplifier
 Transmitters & Fiber Laser
 Testing Equipment
 WDM & DWDM System



Specifications

Parameters	Unit	Single Stage	Dual Stage
Center Wavelength	nm	1750	
Peak isolation	dB	40	55
Min Isolation ($\lambda c \pm 15\text{nm}, 23^\circ\text{C}$)	dB	25	44
Typ. IL ($\lambda c \pm 20\text{nm}, 23^\circ\text{C}$)	dB	0.45	0.55
Insertion Loss ($\lambda c \pm 20\text{nm}, -5 \sim +70^\circ\text{C}$)	dB	≤ 0.60	≤ 0.70
Polarization Dependent Loss (PDL) (for SMF)	dB	≤ 0.05	≤ 0.10
PER (for PMF)	Both Axes Pass	dB ≥ 20	
	Fast Axis Blocked	dB ≥ 23	
Return Loss (Input / Output) (RL)	dB	$\geq 60/55$	$\geq 60/55$
Fiber Type		SMF-28e, PM1550	
Max Power Handling CW	W	1, 2, 3, 5, 10, 20	
Operating Temperature	$^\circ\text{C}$	$-0 \sim +75$	
Storage Temperature	$^\circ\text{C}$	$-40 \sim +85$	

Above data test at room temperature without connectors. With connectors, IL+0.3dB, RL-5dB, PER-2dB.

Optical Power 1W only after connector added.

Default connector key is aligned to slow axis.

Default FC connector key width 2.02mm (narrow key), 2.12mm (wide key) available on request.

Typical Spectrum

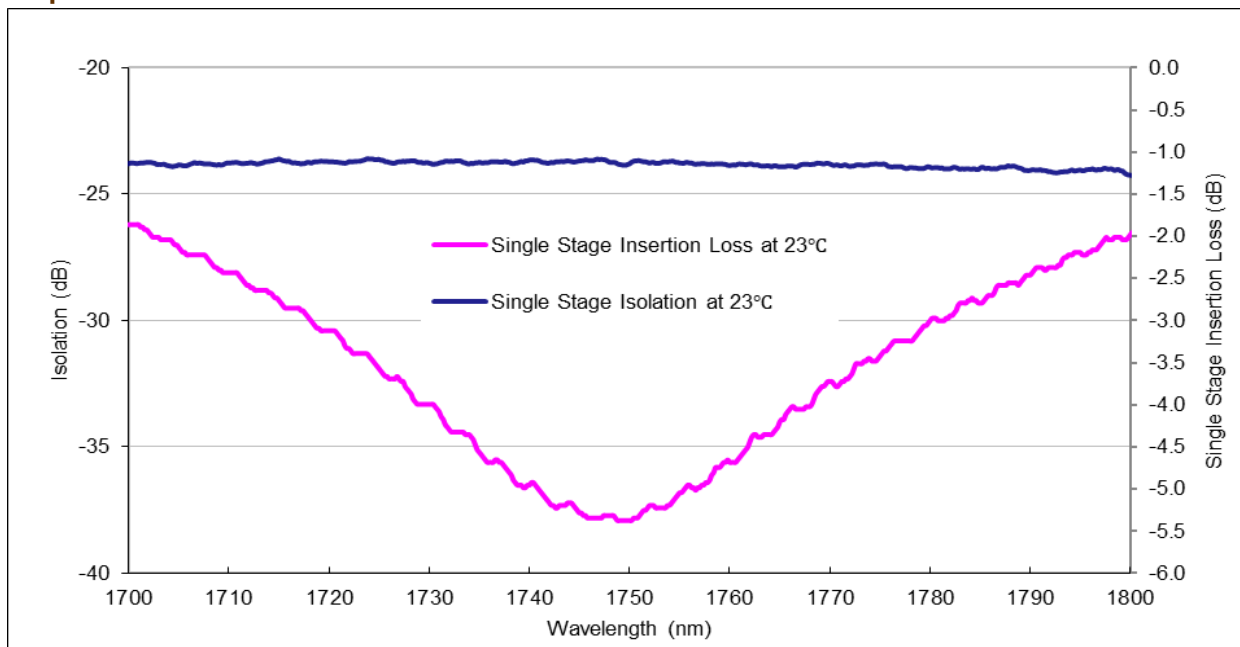

Package Information

Fiber Length	1m, others on request		
Pigtail Type	250 μm Bare Fiber	900 μm Loose Tube	2mm/3mm Loose Cable
Dimensions(mm)	$\phi 5.5 \times 35, 80 \times 12 \times 10$	$\phi 5.5 \times 35, 80 \times 12 \times 10$	90x16x9
Approx Weight (g)	35	50	65

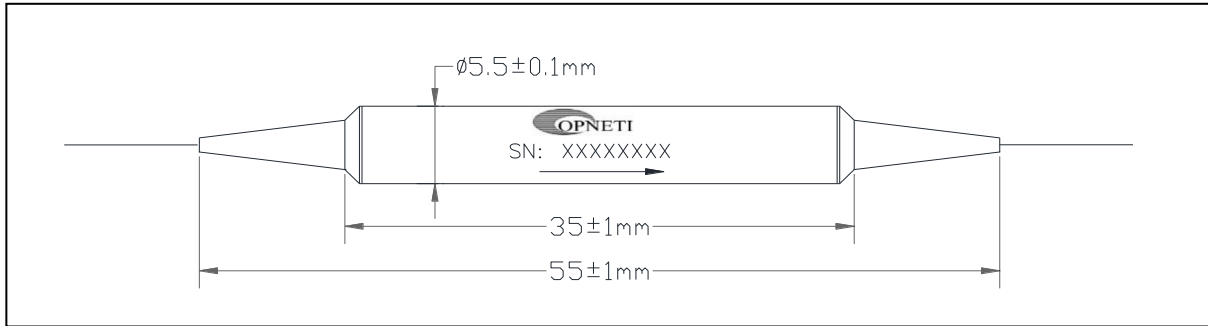

for 1~5 W

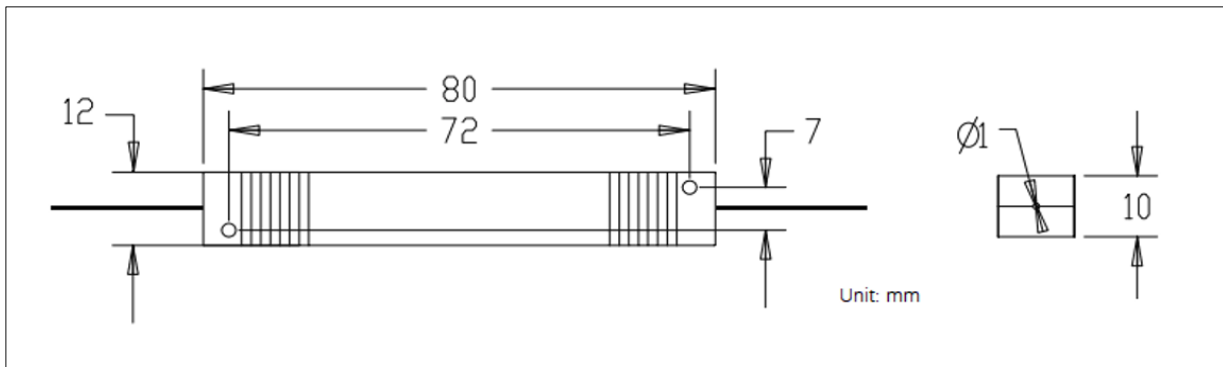

for 6~20W

Ordering Information

HPIS- ①-②②②②-③-④④④-⑤-⑥-⑦⑦-⑧⑧⑧⑧⑧-⑨⑨
 HPMIS-

①	Type	S=Single Stage; D=Dual Stage;
②	Wavelength	1750;
③	Axis Alignment	F=Fast Axis Blocked; B=Both Axes Working;
④	Pigtail Type	250=250μm Fiber; 900=900μm Loose Tube; 2000=2mm Loose Cable; 3000=3mm Loose Cable;
⑤	Fiber Type	1=SMF-28e; P15=PM1550;
⑥	Fiber Length	1=1m; XX=other;
⑦	Connector	NE=None; FA=FC/APC; FC=FC/UPC; SA=SC/APC; SC=SC/UPC; LC=LC/UPC; XX=Others;
⑧	Package size	5.5x35; 80x12x10;
⑨	Power Handling	1W; 2W; 3W; 5W; 10W; 20W